

09: Differential Electronic Module (DEM)
XC90, 2007, D5244T4, TF-80SC
AWD, L.H.D, YV1CM714671338226, 338226
26/3/2013



PRINT

09: Differential Electronic Module (DEM)

Active On demand
Coupling (AOC)
Clutch unit and
control module
Signals

System overview

Active On demand Coupling (AOC)

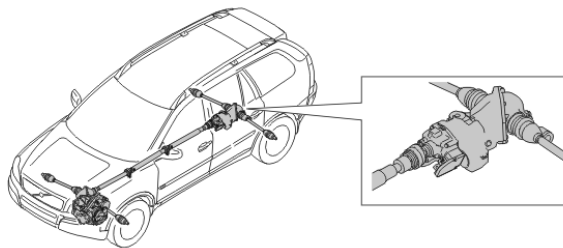

The most important function of Active On demand Coupling (AOC) and its Differential Electronic Module (DEM) is to control the four-wheel **drive** function, i.e. power distribution between front and rear axles. The system consists of a clutch assembly with a mechanical, hydraulic and electronic section. The clutch unit is located on the rear axle, between the **final drive** and the propeller shaft. The mechanical section is driven by the propeller shaft. The hydraulic section is driven by the difference in speed arising between propeller shaft rotation and rear axle rotation.

Active On demand Coupling (AOC) enables the following characteristics:

- **Permanent four-wheel drive** with electronic control of transferred torque.
- A driving character equivalent to front-wheel **drive**.
- Rapid reactions.
- No opposing forces when maneuvering or parking.
- The system is not so sensitive to differences between the tires, e.g. when driving with the spare wheel.
- Not sensitive to towing with an axle lifted.
- Not sensitive to brake testing on a chassis dynamometer.

Clutch unit and control module

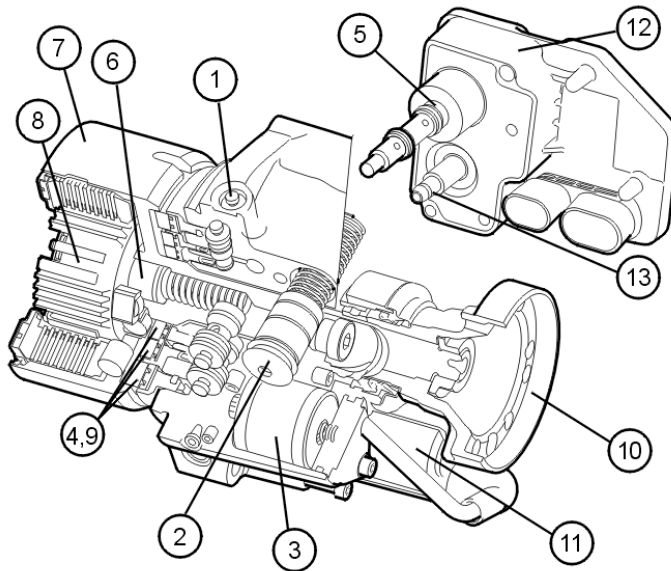

The hydraulic section consists of 1-5, the mechanical consists of 6-10 and the electronic section consists of 11-13:

1. Pressure valves
2. Accumulator
3. Oil filter
4. Ring pistons
5. Control valve/axial solenoid
6. Input shaft
7. Inner and outer wet clutch plates
8. Inner clutch hub with sine shape cam disc
9. Rollers with ring pistons
10. Output shaft
11. Electrical feed pump
12. Differential Electronic Module (DEM)
13. Oil pressure and temperature sensor

The Differential Electronic Module (DEM) is fitted on

the clutch unit housing.

The Differential Electronic Module (DEM) communicates with other control modules via Controller Area Network (CAN) communication:

The control module has an integrated diagnostic system.

Signals

The table below summarizes input and output signals to and from the Differential Electronic Module (DEM). The illustration below displays the same information with the Volvo component designations.

Input signals	Output signals
<p>Directly connected:</p> <ul style="list-style-type: none"> ■ Oil pressure and temperature sensor 	<p>Directly connected: (supply voltage unless otherwise specified)</p> <ul style="list-style-type: none"> ■ Electrical feed pump ■ Axial solenoid - pulse width modulated (PWM) signal
<p>Via Controller Area Network (CAN) communication:</p> <ul style="list-style-type: none"> ■ Central Electronic Module (CEM) (4/56), informs on the position of the ignition key and reverse gear status amongst other things. ■ Brake Control Module (BCM) (4/16), informs on the speed of the wheels from the wheel speed sensors and ABS modulation status amongst other things. ■ Driver Information Module (DIM) (5/1), informs on parking brake switch status. ■ Engine Control Module (ECM) (4/46), informs on engine speed, driver engine torque request, 	<p>Via Controller Area Network (CAN) communication:</p> <ul style="list-style-type: none"> ■ Brake Control Module (BCM) (4/16), receives information on clutch unit status and torque transferred to the rear axle. ■ Central Electronic Module (CEM) (4/56), receives information on the diagnostic status of the Differential Electronic Module (DEM).

calculated engine torque,
 accelerator pedal position, stop
 lamp switch status and clutch
 pedal switch status, amongst other
 things.

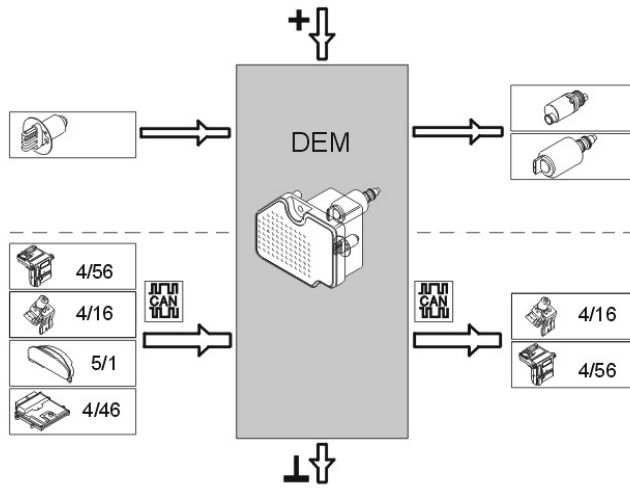

26/3/2013

PRINT